



**Robert Bosch GmbH**  
Power Tools Division  
70745 Leinfelden-Echterdingen  
Germany

[www.bosch-pt.com](http://www.bosch-pt.com)

2 609 140 816 (2010.10) O / 282 UNI



2 609 140 816

## GDR | GDS Professional

14,4 V-Li | 18 V-Li



<b>de</b> Originalbetriebsanleitung	<b>el</b> Πρωτότυπο οδηγιών χρήσης	<b>sr</b> Originalno uputstvo za rad
<b>en</b> Original instructions	<b>tr</b> Orijinal işletme talimatı	<b>sl</b> Izvirna navodila
<b>fr</b> Notice originale	<b>pl</b> Instrukcja oryginalna	<b>hr</b> Originalne upute za rad
<b>es</b> Manual original	<b>cs</b> Původní návod k používání	<b>et</b> Algupärane kasutusjuhend
<b>pt</b> Manual original	<b>sk</b> Pôvodný návod na použitie	<b>lv</b> Instrukcijas oriģinālvalodā
<b>it</b> Istruzioni originali	<b>hu</b> Eredeti használati utasítás	<b>lt</b> Originali instrukcija
<b>nl</b> Oorspronkelijke gebruiksaanwijzing	<b>ru</b> Оригинальное руководство по эксплуатации	<b>ar</b> تعليمات التشغيل الأصلية
<b>da</b> Original brugsanvisning	<b>uk</b> Оригінальна інструкція з експлуатації	<b>fa</b> راهنمای طرز کار اصلی
<b>sv</b> Bruksanvisning i original	<b>ro</b> Instrucțiuni originale	
<b>no</b> Original driftsinstruks	<b>bg</b> Оригинална инструкция	
<b>fi</b> Alkuperäiset ohjeet		



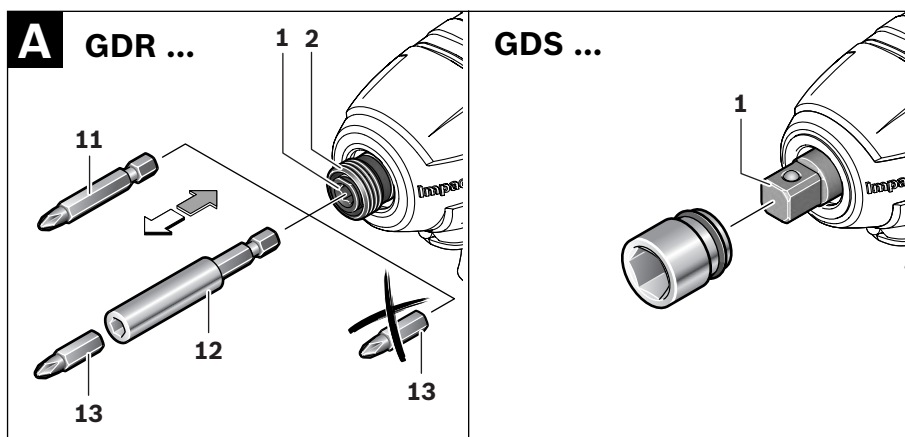
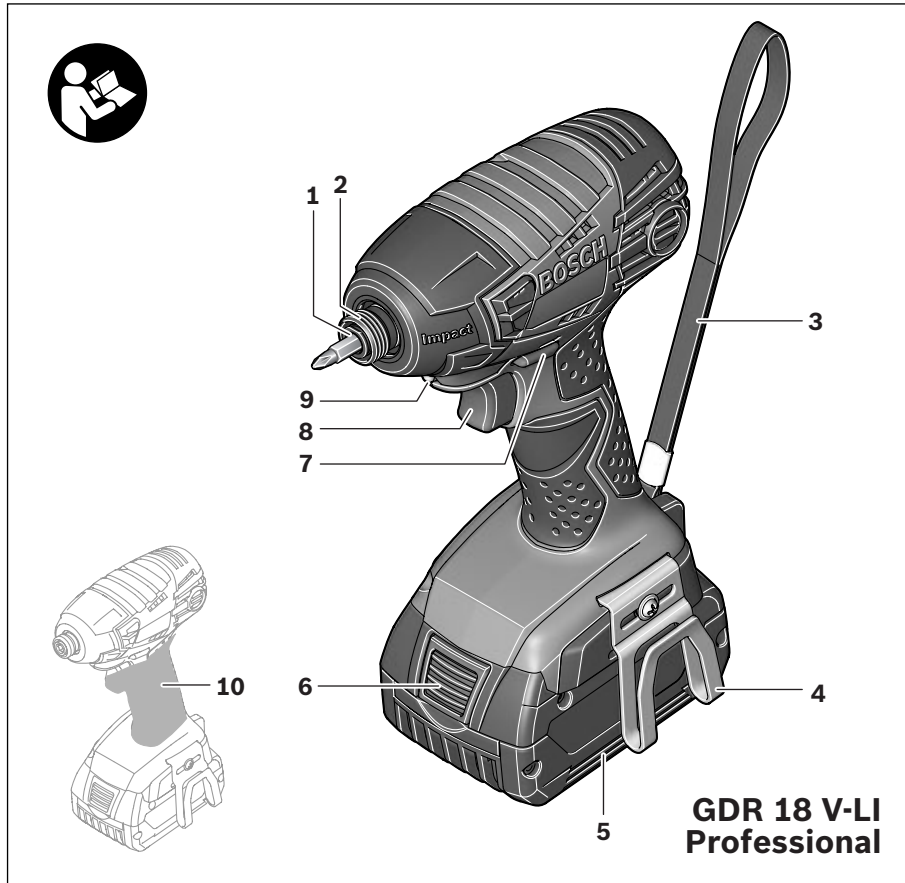

5 |

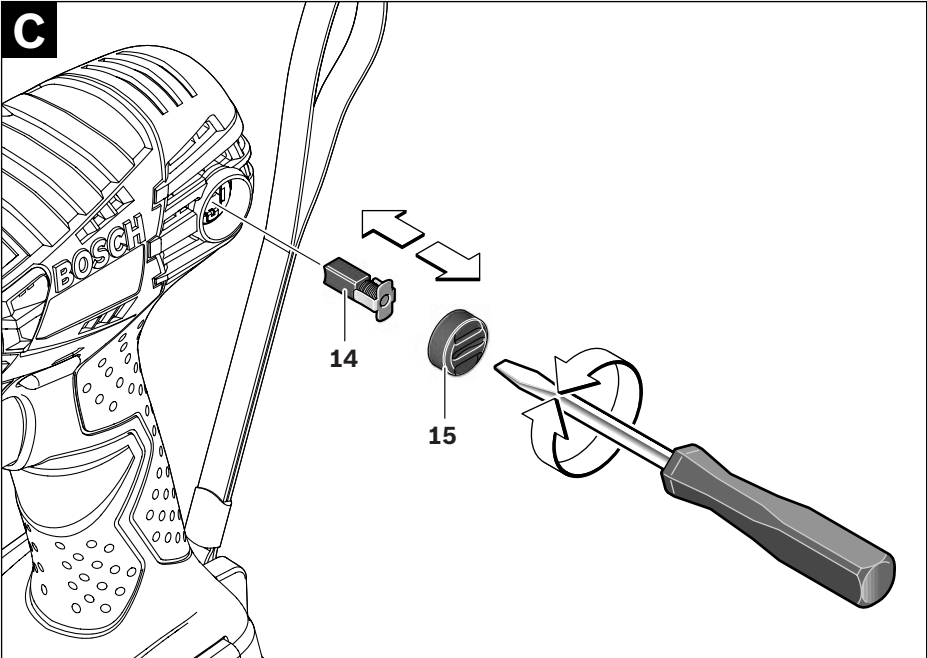
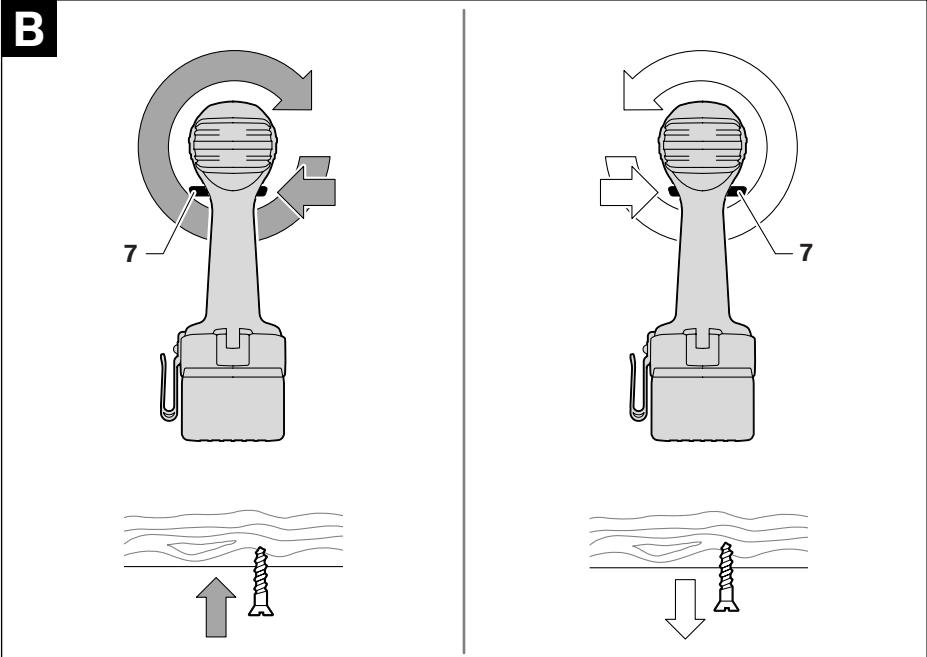

## Safety Notes

### General Power Tool Safety Warnings

**⚠ WARNING** Read all safety warnings and all instructions. Failure to follow the warnings and instructions may result in electric shock, fire and/or serious injury.

Save all warnings and instructions for future reference.

The term “power tool” in the warnings refers to your mains-operated (corded) power tool or battery-operated (cordless) power tool.

#### 1) Work area safety

- a) **Keep work area clean and well lit.** Cluttered or dark areas invite accidents.
- b) **Do not operate power tools in explosive atmospheres, such as in the presence of flammable liquids, gases or dust.** Power tools create sparks which may ignite the dust or fumes.
- c) **Keep children and bystanders away while operating a power tool.** Distractions can cause you to lose control.

#### 2) Electrical safety

- a) **Power tool plugs must match the outlet. Never modify the plug in any way. Do not use any adapter plugs with earthed (grounded) power tools.** Unmodified plugs and matching outlets will reduce risk of electric shock.
- b) **Avoid body contact with earthed or grounded surfaces, such as pipes, radiators, ranges and refrigerators.** There is an increased risk of electric shock if your body is earthed or grounded.
- c) **Do not expose power tools to rain or wet conditions.** Water entering a power tool will increase the risk of electric shock.
- d) **Do not abuse the cord. Never use the cord for carrying, pulling or unplugging the power tool. Keep cord away from heat, oil, sharp edges and moving parts.** Damaged or entangled cords increase the risk of electric shock.

e) **When operating a power tool outdoors, use an extension cord suitable for outdoor use.** Use of a cord suitable for outdoor use reduces the risk of electric shock.

f) **If operating a power tool in a damp location is unavoidable, use a residual current device (RCD) protected supply.** Use of an RCD reduces the risk of electric shock.

#### 3) Personal safety

- a) **Stay alert, watch what you are doing and use common sense when operating a power tool. Do not use a power tool while you are tired or under the influence of drugs, alcohol or medication.** A moment of inattention while operating power tools may result in serious personal injury.
- b) **Use personal protective equipment. Always wear eye protection.** Protective equipment such as dust mask, non-skid safety shoes, hard hat, or hearing protection used for appropriate conditions will reduce personal injuries.
- c) **Prevent unintentional starting. Ensure the switch is in the off-position before connecting to power source and/or battery pack, picking up or carrying the tool.** Carrying power tools with your finger on the switch or energising power tools that have the switch on invites accidents.
- d) **Remove any adjusting key or wrench before turning the power tool on.** A wrench or a key left attached to a rotating part of the power tool may result in personal injury.
- e) **Do not overreach. Keep proper footing and balance at all times.** This enables better control of the power tool in unexpected situations.
- f) **Dress properly. Do not wear loose clothing or jewellery. Keep your hair, clothing and gloves away from moving parts.** Loose clothes, jewellery or long hair can be caught in moving parts.

- g) If devices are provided for the connection of dust extraction and collection facilities, ensure these are connected and properly used.** Use of dust collection can reduce dust-related hazards.
- 4) Power tool use and care**
- a) Do not force the power tool. Use the correct power tool for your application.** The correct power tool will do the job better and safer at the rate for which it was designed.
- b) Do not use the power tool if the switch does not turn it on and off.** Any power tool that cannot be controlled with the switch is dangerous and must be repaired.
- c) Disconnect the plug from the power source and/or the battery pack from the power tool before making any adjustments, changing accessories, or storing power tools.** Such preventive safety measures reduce the risk of starting the power tool accidentally.
- d) Store idle power tools out of the reach of children and do not allow persons unfamiliar with the power tool or these instructions to operate the power tool.** Power tools are dangerous in the hands of untrained users.
- e) Maintain power tools. Check for misalignment or binding of moving parts, breakage of parts and any other condition that may affect the power tool's operation. If damaged, have the power tool repaired before use.** Many accidents are caused by poorly maintained power tools.
- f) Keep cutting tools sharp and clean.** Properly maintained cutting tools with sharp cutting edges are less likely to bind and are easier to control.
- g) Use the power tool, accessories and tool bits etc. in accordance with these instructions, taking into account the working conditions and the work to be performed.** Use of the power tool for operations different from those intended could result in a hazardous situation.
- 5) Battery tool use and care**
- a) Recharge only with the charger specified by the manufacturer.** A charger that is suitable for one type of battery pack may create a risk of fire when used with another battery pack.
- b) Use power tools only with specifically designated battery packs.** Use of any other battery packs may create a risk of injury and fire.
- c) When battery pack is not in use, keep it away from other metal objects, like paper clips, coins, keys, nails, screws or other small metal objects, that can make a connection from one terminal to another.** Shorting the battery terminals together may cause burns or a fire.
- d) Under abusive conditions, liquid may be ejected from the battery; avoid contact. If contact accidentally occurs, flush with water. If liquid contacts eyes, additionally seek medical help.** Liquid ejected from the battery may cause irritation or burns.
- 6) Service**
- a) Have your power tool serviced by a qualified repair person using only identical replacement parts.** This will ensure that the safety of the power tool is maintained.
- 
- Safety Warnings for Screwdriver**
- ▶ **Hold power tool by insulated gripping surfaces, when performing an operation where the fastener may contact hidden wiring.** Fasteners contacting a "live" wire may make exposed metal parts of the power tool "live" and could give the operator an electric shock.
  - ▶ **Secure the workpiece.** A workpiece clamped with clamping devices or in a vice is held more secure than by hand.
  - ▶ **Always wait until the machine has come to a complete stop before placing it down.** The tool insert can jam and lead to loss of control over the power tool.
  - ▶ **Do not open the battery.** Danger of short-circuiting.



**Protect the battery against heat, e. g., against continuous intense sunlight, fire, water, and moisture.** Danger of explosion.

- ▶ **In case of damage and improper use of the battery, vapours may be emitted. Provide for fresh air and seek medical help in case of complaints.** The vapours can irritate the respiratory system.
- ▶ **Use the battery only in conjunction with your Bosch power tool.** This measure alone protects the battery against dangerous overload.
- ▶ **Use only original Bosch batteries with the voltage listed on the nameplate of your power tool.** When using other batteries, e. g. imitations, reconditioned batteries or other brands, there is danger of injury as well as property damage through exploding batteries.

## Functional Description



**Read all safety warnings and all instructions.** Failure to follow the warnings and instructions may result in electric shock, fire and/or serious injury.

While reading the operating instructions, unfold the graphics page for the machine and leave it open.

## Intended Use

The machine is intended for driving in and loosening screws and bolts as well as for tightening and loosening nuts within the respective range of dimension.

## Product Features

The numbering of the product features refers to the illustration of the machine on the graphics page.

- 1 Tool holder
- 2 Locking sleeve
- 3 Carrying strap
- 4 Belt clip\*
- 5 Battery\*
- 6 Battery unlocking button\*
- 7 Rotational direction switch
- 8 On/Off switch
- 9 "PowerLight"
- 10 Handle (insulated gripping surface)
- 11 Screwdriver bit with ball catch\*
- 12 Universal bit holder\*
- 13 Screwdriver bit\*
- 14 Carbon brushes
- 15 Cover lid

\*Accessories shown or described are not part of the standard delivery scope of the product. A complete overview of accessories can be found in our accessories program.

## Declaration of Conformity

We declare under our sole responsibility that the product described under "Technical Data" is in conformity with the following standards or standardization documents: EN 60745 according to the provisions of the directives 2004/108/EC, 2006/42/EC.

Technical file at:  
Robert Bosch GmbH, PT/ESC,  
D-70745 Leinfelden-Echterdingen

Dr. Egbert Schneider Senior Vice President Engineering	Dr. Eckerhard Strötgen Head of Product Certification
--	--

*Dr. Egbert Schneider* *Dr. Eckerhard Strötgen*

Robert Bosch GmbH, Power Tools Division  
D-70745 Leinfelden-Echterdingen  
20.09.2010

### Noise/Vibration Information

Measured sound values determined according to EN 60745.

Typically the A-weighted noise levels of the product are: Sound pressure level 96 dB(A); Sound power level 107 dB(A). Uncertainty K=3 dB.

#### Wear hearing protection!

Vibration total values (triax vector sum) determined according to EN 60745:

Impact tightening of fasteners of the maximum capacity of the tool: Vibration emission value  $a_h = 12 \text{ m/s}^2$ , Uncertainty K=1.5  $\text{m/s}^2$ .

The vibration emission level given in this information sheet has been measured in accordance with a standardised test given in EN 60745 and may be used to compare one tool with another. It may be used for a preliminary assessment of exposure.

The declared vibration emission level represents the main applications of the tool. However if the tool is used for different applications, with different accessories or poorly maintained, the vibration emission may differ. This may significantly increase the exposure level over the total working period.

An estimation of the level of exposure to vibration should also take into account the times when the tool is switched off or when it is running but not actually doing the job. This may significantly reduce the exposure level over the total working period.

Identify additional safety measures to protect the operator from the effects of vibration such as: maintain the tool and the accessories, keep the hands warm, organisation of work patterns.

### Technical Data

Cordless Impact Screwdriver		GDR 14,4 V-LI Professional		GDR 18 V-LI Professional	
Article number		3 601 JA1 4..	3 601 JA1 4..	3 601 JA1 3..	3 601 JA1 3..
with battery		"premium"	"compact"	"premium"	"compact"
Rated voltage	V=	14.4	14.4	18	18
No-load speed	$\text{min}^{-1}$	0 – 2800	0 – 2800	0 – 2800	0 – 2800
Impact rate	$\text{min}^{-1}$	0 – 3200	0 – 3200	0 – 3200	0 – 3200
Maximum torque, hard screwdriving application according to ISO 5393	Nm	150	150	160	160
Bolt size	mm	M6 – M14	M6 – M14	M6 – M14	M6 – M14
Tool holder		¼" hexagon socket	¼" hexagon socket	¼" hexagon socket	¼" hexagon socket
Weight according to EPTA-Procedure 01/2003	kg	1.6	1.4	1.7	1.5

Cordless Impact Screwdriver	GDS 14,4 V-Li Professional		GDS 18 V-Li Professional	
	3 601 JA1 T..	3 601 JA1 T..	3 601 JA1 S..	3 601 JA1 S..
with battery	"premium"	"compact"	"premium"	"compact"
Rated voltage	V= 14.4	14.4	18	18
No-load speed	min <sup>-1</sup> 0–2800	0–2800	0–2800	0–2800
Impact rate	min <sup>-1</sup> 0–3200	0–3200	0–3200	0–3200
Maximum torque, hard screwdriving application according to ISO 5393	Nm 170	170	180	180
Bolt size	mm M6–M16	M6–M16	M6–M16	M6–M16
Tool holder	■ ½"	■ ½"	■ ½"	■ ½"
Weight according to EPTA-Procedure 01/2003	kg 1.6	1.4	1.7	1.5

Please observe the article number on the type plate of your machine. The trade names of the individual machines may vary.

## Assembly

### Battery Charging

- **Use only the battery chargers listed on the accessories page.** Only these battery chargers are matched to the lithium ion battery of your power tool.

**Note:** The battery is supplied partially charged. To ensure full capacity of the battery, completely charge the battery in the battery charger before using your power tool for the first time.

The lithium ion battery can be charged at any time without reducing its service life. Interrupting the charging procedure does not damage the battery.

The lithium ion battery is protected against deep discharging by the "Electronic Cell Protection (ECP)". When the battery is empty, the machine is switched off by means of a protective circuit: The inserted tool no longer rotates.

**⚠ WARNING** Do not continue to press the On/Off switch after the machine has been automatically switched off. The battery can be damaged.

The battery is equipped with a NTC temperature control which allows charging only within a temperature range of between 0 °C and 45 °C. A long battery service life is achieved in this manner.

Observe the notes for disposal.

### Removing the Battery

The battery **5** is equipped with two locking levels that should prevent the battery from falling out when pushing the battery unlocking button **6** unintentionally. As long as the battery is inserted in the power tool, it is held in position by means of a spring.

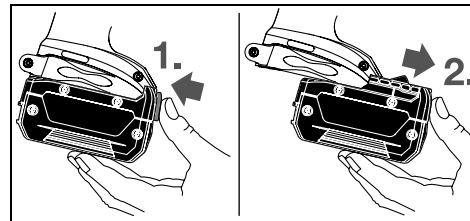

To remove the battery **5**, press the unlocking button **6** and pull out the battery toward the front. **Do not exert any force.**



### Changing the Tool (see figure A)

- ▶ **Before any work on the machine (e. g., maintenance, tool change, etc.) as well as during transport and storage, set the rotational direction switch to the centre position.** Unintentional actuation of the On/Off switch can lead to injuries.

#### GDR 14,4 V-LI/GDR 18 V-LI: Inserting

Pull the locking sleeve **2** forward, push the insert tool to the stop into the tool holder **1** and release the locking sleeve **2** to lock the insert tool.

Use only screwdriver bits with ball catch **11** (DIN 3126-E6.3). Other screwdriver bits **13** can be used with a universal bit holder with ball catch **12**.

#### Removing

Pull the locking sleeve **2** forward and remove the insert tool.

#### GDS 14,4 V-LI/GDS 18 V-LI:

- ▶ **When working with an application tool, pay attention that the application tool is firmly seated on the tool holder.** When the application tool is not firmly connected with the tool holder, it can come loose again and not be controlled.

Slide the application tool onto the square drive of the tool holder **1**.

## Operation

### Method of Operation

The tool holder **1** with the tool is driven by an electric motor via a gear and impact mechanism.

The working procedure is divided into two phases:

**Screwing in and tightening** (impact mechanism in action).

The impact mechanism is activated as soon as the screwed connection runs tight and thus load is put on the motor. In this instance, the impact

mechanism converts the power of the motor to steady rotary impacts. When loosening screws or nuts, the process is reversed.

### Starting Operation

#### Inserting the Battery

- ▶ **Use only original Bosch lithium ion batteries with the voltage listed on the nameplate of your power tool.** Using other batteries can lead to injuries and pose a fire hazard.

Set the rotational direction switch **7** to the centre position to protect the power tool against accidental starting.

Insert the charged battery **5** from the front into the base of the power tool until the battery is securely locked.

#### Reversing the Rotational Direction (see figure B)

The rotational direction switch **7** is used to reverse the rotational direction of the machine. However, this is not possible with the On/Off switch **8** actuated.

**Right rotation:** For driving in screws and tightening nuts, press the rotational direction switch **7** through to the left stop.

**Left Rotation:** For loosening and unscrewing screws and nuts, press the rotational direction switch **7** through to the right stop.

#### Switching On and Off

To **start** the machine, press the On/Off switch **8** and keep it pressed.

The power light **9** lights up when the On/Off switch **8** is slightly or completely pressed, and allows the work area to be illuminated when lighting conditions are insufficient.

To switch off the machine, **release** the On/Off switch **8**.

#### Adjusting the Speed

The speed of the switched on power tool can be variably adjusted, depending on how far the On/Off switch **8** is pressed.

Light pressure on the On/Off switch **8** results in a low rotational speed. Further pressure on the switch results in an increase in speed.

### Working Advice

- ▶ **Apply the power tool to the screw/nut only when it is switched off.** Rotating tool inserts can slip off.

The torque depends on the impact duration. The maximum achieved torque results from the sum of all individual torques achieved through impact. The maximum torque is achieved after an impact duration of 6–10 seconds. After this duration, the tightening torque is increased only minimally.

The impact duration is to be determined for each required tightening torque. The actually achieved tightening torque is always to be checked with a torque wrench.

#### Screw Applications with Hard, Spring-loaded or Soft Seat

When in a test, the achieved torques in an impact series are measured and transferred into a diagram, resulting in the curve of a torque characteristic. The height of the curve corresponds with the maximum reachable torque, and the steepness indicates the duration in which this is achieved.

A torque gradient depends on the following factors:

- Strength properties of the screws/nuts
- Type of backing (washer, disc spring, seal)
- Strength properties of the material being screwed/bolted together
- Lubrication conditions at the screw/bolt connection

The following application cases result accordingly:

- A **hard seat** is given for metal-to-metal screw applications with the use of washers. After a relatively short impact duration, the maximum torque is reached (steep characteristic curve). Unnecessary long impact duration only causes damage to the machine.
- A **spring-loaded seat** is given for metal-to-metal screw applications, however with the use of spring washers, disc springs, studs or screws/nuts with conical seat as well as when using extensions.
- A **soft seat** is given for screw applications, e. g., metal on wood or when using lead washers or fibre washers as backing.

For a spring-loaded seat as well as for a soft seat, the maximum tightening torque is lower than for a hard seat. Also, a clearly longer impact duration is required.

### Reference Values for Maximum Screw/Bolt Tightening Torques

Calculated from the tensional cross-section; utilization of the yield point 90% (with friction coefficient  $\mu_{\text{total}} = 0.12$ ). As a control measure, always check the tightening torque with a torque wrench.

Property Classes according to DIN 267	Standard Screws/Bolts								High-strength Bolts		
	3.6	4.6	5.6	4.8	6.6	5.8	6.8	6.9	8.8	10.9	12.9
M 6	2.71	3.61	4.52	4.8	5.42	6.02	7.22	8.13	9.7	13.6	16.2
M 8	6.57	8.7	11	11.6	13.1	14.6	17.5	19.7	23	33	39
M 10	13	17.5	22	23	26	29	35	39	47	65	78
M 12	22.6	30	37.6	40	45	50	60	67	80	113	135
M 14	36	48	60	65	72	79	95	107	130	180	215
M 16	55	73	92	98	110	122	147	165	196	275	330

**Tips**

Before screwing larger, longer screws into hard materials, it is advisable to predrill a pilot hole with the core diameter of the thread to approx.  $\frac{2}{3}$  of the screw length.

**Belt Clip**

With the belt clip **4**, the machine can be hung onto a belt. The user has both hands free and the machine is always at hand.

**Recommendations for Optimal Handling of the Battery**

Protect the battery against moisture and water.

Store the battery only within a temperature range between 0 °C and 45 °C. As an example, do not leave the battery in the car in summer.

Occasionally clean the venting slots of the battery using a soft, clean and dry brush.

A significantly reduced working period after charging indicates that the battery is used and must be replaced.

Observe the notes for disposal.

- Unscrew the caps **15** using a suitable screwdriver.
- Replace the spring-loaded carbon brushes **14** and screw the caps back on again.

If the machine should fail despite the care taken in manufacturing and testing procedures, repair should be carried out by an after-sales service centre for Bosch power tools.

In all correspondence and spare parts order, please always include the 10-digit article number given on the type plate of the machine.

**After-sales Service and Customer Assistance**

Our after-sales service responds to your questions concerning maintenance and repair of your product as well as spare parts. Exploded views and information on spare parts can also be found under:

**www.bosch-pt.com**

Our customer service representatives can answer your questions concerning possible applications and adjustment of products and accessories.

**Great Britain**

Robert Bosch Ltd. (B.S.C.)  
P.O. Box 98  
Broadwater Park  
North Orbital Road  
Denham  
Uxbridge  
UB 9 5HJ  
Tel. Service: +44 (0844) 736 0109  
Fax: +44 (0844) 736 0146  
E-Mail: boschservicecentre@bosch.com

**Ireland**

Origo Ltd.  
Unit 23 Magna Drive  
Magna Business Park  
City West  
Dublin 24  
Tel. Service: +353 (01) 4 66 67 00  
Fax: +353 (01) 4 66 68 88

**Maintenance and Service****Maintenance and Cleaning**

- ▶ **Before any work on the machine (e. g., maintenance, tool change, etc.) as well as during transport and storage, set the rotational direction switch to the centre position.** Unintentional actuation of the On/Off switch can lead to injuries.

- ▶ **For safe and proper working, always keep the machine and ventilation slots clean.**

**Replacing the Carbon Brushes (see figure C)**

Check the length of the carbon brushes approx. every 2–3 months and replace the carbon brushes if required.

Never replace only a single carbon brush!

**Note:** Use only carbon brushes supplied by Bosch and intended specifically for your product.

**Australia, New Zealand and Pacific Islands**

Robert Bosch Australia Pty. Ltd.  
 Power Tools  
 Locked Bag 66  
 Clayton South VIC 3169  
 Customer Contact Center  
 Inside Australia:  
 Phone: +61 (01300) 307 044  
 Fax: +61 (01300) 307 045  
 Inside New Zealand:  
 Phone: +64 (0800) 543 353  
 Fax: +64 (0800) 428 570  
 Outside AU and NZ:  
 Phone: +61 (03) 9541 5555  
 www.bosch.com.au

**Republic of South Africa****Customer service**

Hotline: +27 (011) 6 51 96 00

**Gauteng – BSC Service Centre**

35 Roper Street, New Centre  
 Johannesburg  
 Tel.: +27 (011) 4 93 93 75  
 Fax: +27 (011) 4 93 01 26  
 E-Mail: bsctools@icon.co.za

**KZN – BSC Service Centre**

Unit E, Almar Centre  
 143 Crompton Street  
 Pinetown  
 Tel.: +27 (031) 7 01 21 20  
 Fax: +27 (031) 7 01 24 46  
 E-Mail: bsc.dur@za.bosch.com

**Western Cape – BSC Service Centre**

Democracy Way, Prosperity Park  
 Milnerton  
 Tel.: +27 (021) 5 51 25 77  
 Fax: +27 (021) 5 51 32 23  
 E-Mail: bsc@zsd.co.za

**Bosch Headquarters**

Midrand, Gauteng  
 Tel.: +27 (011) 6 51 96 00  
 Fax: +27 (011) 6 51 98 80  
 E-Mail: rbsa-hq.pts@za.bosch.com

**Transport**

Dispatch batteries only when the housing is undamaged. Tape or mask off open contacts and pack up the battery in such a manner that it cannot move around in the packaging. When dispatching lithium-ion batteries, compulsory labeling may be required. Please observe the respective national regulations.

**Disposal**

The machine, accessories and packaging should be sorted for environmental-friendly recycling.

Do not dispose of power tools and batteries/rechargeable batteries into household waste!

**Only for EC countries:**

According to the European Guideline 2002/96/EC, power tools that are no longer usable, and according to the European Guideline 2006/66/EC, defective or used battery packs/batteries, must be collected separately and disposed of in an environmentally correct manner.

Batteries no longer suitable for use can be directly returned at:

**Great Britain**

Robert Bosch Ltd. (B.S.C.)  
 P.O. Box 98  
 Broadwater Park  
 North Orbital Road  
 Denham  
 Uxbridge  
 UB 9 5HJ  
 Tel. Service: +44 (0844) 736 0109  
 Fax: +44 (0844) 736 0146  
 E-Mail: boschservicecentre@bosch.com

**Battery packs/batteries:****Li-ion:**

Please observe the instructions in section "Transport", page 24.

Subject to change without notice.